

# SFP200MOD

## Precision Current and Voltage Measurement Module

The SFP200MOD is a shunt-based, automotive rated, precision module capable of measuring currents from mA up to 1500 A continuous. The module incorporates SFP200 IC with the Sendyne SFP 18  $\mu\Omega$  shunt, and achieves an accuracy of better than  $\pm 1.0\%$  (typically  $\pm 0.5\%$ ) over the entire operating temperature range of  $-40\text{ }^\circ\text{C}$  to  $+125\text{ }^\circ\text{C}$ .

The module simultaneously measures bi-directional DC current through the shunt and three high voltage channels (800 V nominal, 1000 V / channel max), as well as providing separate charge, discharge and total Coulomb output. The module is fully isolated and capable of attachment onto either the high side or low side of a battery.

The module can be powered from a voltage supply rail of nominal +5 V or +5 V to + 53 V. The module automatically compensates for the shunt's varying resistance relative to temperature. With the exception of connectors, all components on the module are AEC-Q100 compliant. Communications are achieved via an isolated CAN 2.0B interface (500 kbits/s). The module is an implementation of the SFP200 IC reference design.

### Highlights

#### Superior Accuracy

- Patented dynamic self-calibration algorithm delivers  $\pm 0.5\%$  accuracy, ensuring accurate SOC and EV range calculation
- Helps eliminate errors over time

#### Reduced Power Losses and Lower Self-Heating

- Ultra-low resistance for low system losses & simplified thermal management
- 18  $\mu\Omega$  shunt resistor thermal losses are 28% lower compared to a 25  $\mu\Omega$  shunt; 64% lower compared to a 50  $\mu\Omega$  shunt

#### Simple, Cost-effective Integration

- Ready-to-use; calibrated and compensated
- No production calibration necessary

#### Flexible Configuration

- Feature set can be customized

### Applications



### Features

- Achieves better than  $\pm 1.0\%$  (typically  $\pm 0.5\%$ ) accuracy for current measurement
- Measures three high-voltage potentials (800 V nominal, 1000 V / channel max)
- Measures currents from mA to 1500 A
- Communications via an isolated CAN2.0B interface (500 kbits/s)
- Automotive temperature range of  $-40\text{ }^\circ\text{C}$  to  $+125\text{ }^\circ\text{C}$
- Low power consumption
- Isolated front end for "high" or "low" side current sensing and attenuation of system-induced noise
- Utilizes Sendyne's patented zero offset functionality
- Automatically compensates for the shunt's varying resistance relative to temperature (Gain Error)
- Built-in calibration for voltage measurements
- Separate charge, discharge, and total Coulomb counters
- All components except connectors are AEC-Q100 compliant
- Implementation of SFP200 IC reference design

# SFP200MOD Technical Specifications

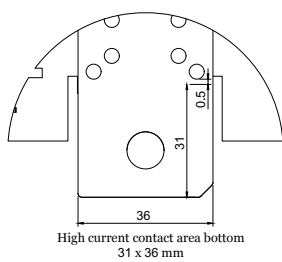
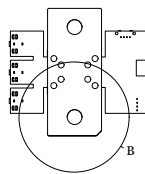
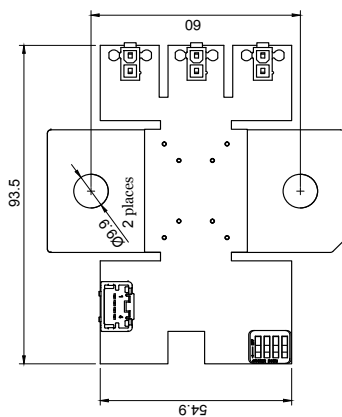
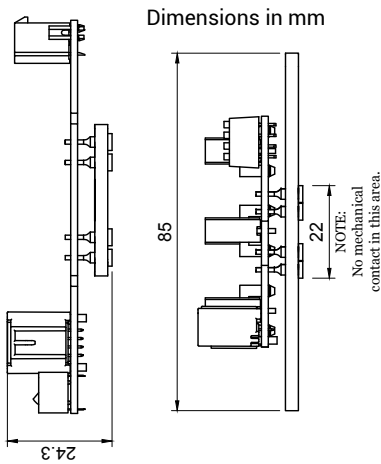

## Operating Specifications

Parameters	Value
Shunt value	18 $\mu$ Ohm
Power supply	Power supply accepts input of anywhere from +5 V to +53 V
Interface	CAN 2.0B isolated, 120 $\Omega$ terminated
Current measurement range	$\pm$ 600 A continuous / $\pm$ 1500 A (70 s) when attached to 108 mm <sup>2</sup> busbars, $<$ $\pm$ 1.0 % error
Rating	Automotive
Power consumption	$<$ 300 mW at +5V power supply

## Electrical Specifications

Parameter	Min	Typical	Max	Units	Conditions / Comments
<b>Power and General</b>					
Shunt & electronics operating temperature range	-40		+125	$^{\circ}$ C	
Operating temperature range for connectors	-40		+105	$^{\circ}$ C	
Supply Voltage	4.5	5	5.5	V	
			53	V	
Supply Current			50	mA	
Start-up time		0.5	0.75	s	After initial application of power and power supply stabilization
<b>Current Measurement</b>					
Total Shunt Resistance	16	18	20	$\mu$ $\Omega$	
Nominal Full-scale current		$\pm$ 600		A	Continuous rating in still air at room temperature of 23 $^{\circ}$ C with module connected to 108 mm <sup>2</sup> busbars on each side
Peak Full-scale current	$\pm$ 1514	$\pm$ 1717		A	Maximum current value that is measured without clipping; less than 220 s duration, the same conditions as above
Current offset error*	-50	$<$ $\pm$ 20	+50	mA	Uncalibrated performance, applies over the full operating temperature range
Current noise error*		$<$ 25	50	mA <sub>RMS</sub>	1 Hz reporting rate
Current value error*	-0.25		+0.25	%	Room temperature, test current $\pm$ 20 A or higher
	-0.5		+0.5	%	0 $^{\circ}$ C to +50 $^{\circ}$ C, test current as above
	-1		+1	%	-40 $^{\circ}$ C to +125 $^{\circ}$ C, test current as above
		$\pm$ 1		%	End of life, test current as above
Current measurement resolution		$<$ 100		$\mu$ A	Minimum discernible current change; corresponds to one count of Analog to Digital Converter (ADC), 1 Hz current report rate

\* The combined Total Current Error is the  $\pm$ sum of Current offset error, Current noise error, and [Current value error] x [measured value]. For currents over 100 A the Current offset error and the Current noise error could be omitted from the calculation since they will typically contribute less than 0.05 % to the error.

# SFP200MOD Technical Specifications

Parameter	Min	Typical	Max	Units	Conditions / Comments
Charge measurement resolution		<1		μC	Minimum discernible amount of charge change, 100 Hz report rate
<b>Voltage Measurement</b>					
Nominal Full-scale voltage range		±800		V	In reference to negative terminal of the shunt
Maximum transient voltage	±982	±1002		V	Maximum voltage value measured and reported without clipping or distortion
Voltage offset error	-300	<±50	+300	mV	VX = 0 V, applies over the full ambient operating temperature range, TA = -40 °C to +125 °C
Voltage gain error		<±1		%	Over full operating temperature range, TA = -40 °C to +125 °C
Voltage noise error		<12	30	mV <sub>RMS</sub>	1 Hz reporting rate
Voltage measurement resolution		<1		mV	Minimum discernible voltage change; corresponds to one count of ADC, voltage report rate of 10 Hz or lower
Impedance of the voltage measurement inputs		12		MΩ	Resistive dividers utilized for the voltage inputs consist of four (4) elements connected in-series. Combined Limiting Element Voltage is 2 kV, and combined Maximum Overload Voltage is 4 kV
<b>Temperature Measurement (For shunt temperature measurement)</b>					
Absolute temperature measurement error	-5	±0.5	+5	°C	Built-in temperature sensor for shunt temperature measurements
Temperature measurement resolution			10	m°C	Practical temperature measurement granularity
<b>Isolation</b>					
Test voltage		3		kV <sub>DC</sub>	CAN interface to shunt, 1 min duration
<b>Communication</b>					
Interface	Spec		Speed	Termination	Number of units in the same CAN branch
CAN	2.0B		500 kbits/s	120 Ω	16 (only one unit having CAN termination)

# SFP200MOD Technical Specifications

## CAN Addresses Selection

The module can operate with sixteen (16) different sets of CAN addresses, thus 16 modules can simultaneously reside on the same CAN bus stub. When two or more devices are connected to the same CAN branch, only a single device may have the 120  $\Omega$  termination between the two CAN communications lines (assuming that the Host has the termination at the other end of the transmission line).

The modules are supplied with the termination resistor installed; if more than a single device will reside on the CAN bus, the termination resistor must be removed from all but a single module. This resistor (R39) is located near the middle pins of connector P1, on the opposite side and towards the edge of the PCB. This resistor (0603-sized) can be unsoldered (and re-installed if necessary) or simply snipped-off with small diagonal cutters.

Selection of a specific set of addresses is performed by the activation of one or more switches from the four individual switches on the quad-switch unit. After the state of the switches is changed, it is required that the module is powered down (supply voltage is removed) for 10 seconds, in order for the new settings to be accepted. In other words, any changes made while the unit is powered on will be ignored until the next power-up.

Selected address set follows the switch settings shown in the table below:

**Table for selection of the CAN address set**

Switch 1 (IC pin 4)	Switch 2 (IC pin 3)	Switch 3 (IC pin 2)	Switch 4 (IC pin 1)	Address set	Notes
Off	Off	Off	Off	1	Default
Off	Off	Off	On	2	
Off	Off	On	Off	3	
Off	Off	On	On	4	
Off	On	Off	Off	5	
Off	On	Off	On	6	
Off	On	On	Off	7	
Off	On	On	On	8	
On	Off	Off	Off	9	
On	Off	Off	On	10	
On	Off	On	Off	11	
On	Off	On	On	12	
On	On	Off	Off	13	
On	On	Off	On	14	
On	On	On	Off	15	
On	On	On	On	16	

"Off" signifies a sensing pin is not connected / floating; "On" signifies a sensing pin is shorted to IC's DVSS (local logic GND) potential.

# SFP200MOD Technical Specifications

The Host (controller) communicates with the SFP200 via the CAN interface using the request-response method. The Host issues a message requesting the specific data, and SFP200 responds with that data. For details on the composition of these messages, please see the "SFP200 CAN 2.0B Protocol" document. Requests for data from the Host and the response of the SFP200 are sent using different Extended Message ID values. These values are shown in the table below for the sixteen (16) address sets supported by the IC.

**Table for SFP200 supported Message ID sets**

Address Set	Request Message ID	Response Message ID	Notes
1	0xA100201	0xA100200	Default Address Set
2	0xA100211	0xA100210	
3	0xA100221	0xA100220	
4	0xA100231	0xA100230	
5	0xA100241	0xA100240	
6	0xA100251	0xA100250	
7	0xA100261	0xA100260	
8	0xA100271	0xA100270	
9	0xA100281	0xA100280	
10	0xA100291	0xA100290	
11	0xA1002A1	0xA1002A0	
12	0xA1002B1	0xA1002B0	
13	0xA1002C1	0xA1002C0	
14	0xA1002D1	0xA1002D0	
15	0xA1002E1	0xA1002E0	
16	0xA1002F1	0xA1002F0	

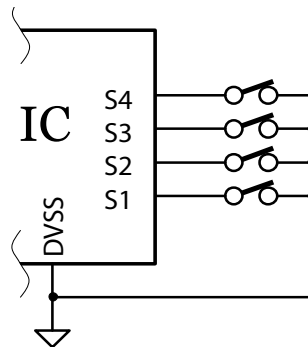

Address selection with switches

# SFP200MOD Technical Specifications

## Connectors

Interface	Manufacturer	Position	Part Number	Description
CAN & power on board	Molex	4	347920040	4 pos. header, Shrouded connector (2.00 mm), Through hole tin
Can & power mating con.	Molex	4	347910040	Use appropriate crimp contacts (available for AWG 22, 24 and 26)
Voltage sensing on board	Molex	2	039299029	MINIFIT JR HDR 02P 94V-0 30AU
Voltage sensing mating con.	Molex	2	039013028	MINIFIT JR RCPT DR SIDETABS 2 CKT 94V-0. Crimp contacts available for AWG 18 to 28

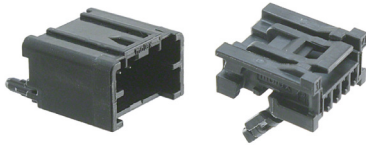

CAN and Power header & mating connectors

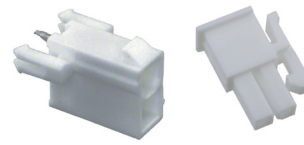

Voltage sensing header & mating connectors

## CAN Connector Pinout Description

Pin Number	Description
Pin 1	GND
Pin 2	CAN HIGH
Pin 3	CAN LOW
Pin 4	VCC

The SFP200MOD uses Molex connectors, part number 347920040 and 39299029. For more details please see the [Molex datasheets](#).

## Measured performance data

Current error over temperature range of  $-40\text{ }^{\circ}\text{C}$  to  $+125\text{ }^{\circ}\text{C}$

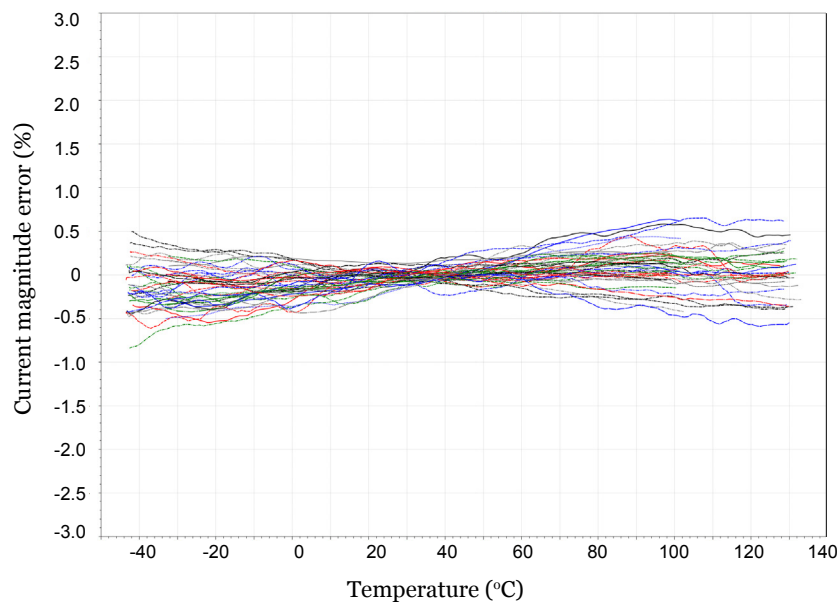

# SFP200MOD Technical Specifications

## Expected Performance Data

SFP Shunt, 18  $\mu\Omega$  Shunt with 108 mm<sup>2</sup> bus-bars

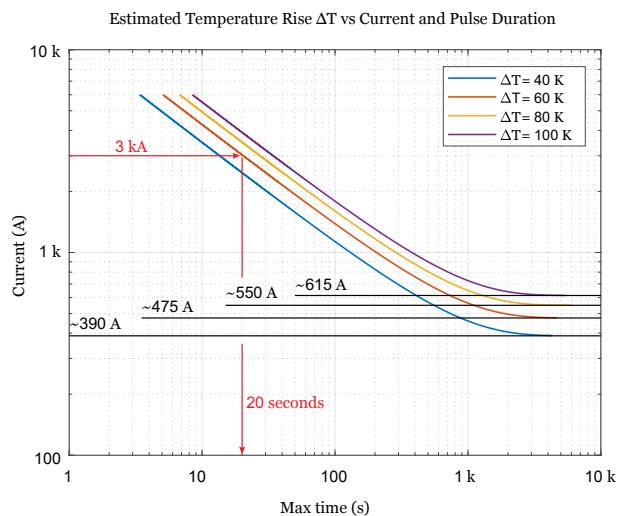

This chart is a representation of results obtained using an effective thermal shunt model for transient thermal response analysis, as developed by Sendyne's modeling team. The model accounts for specific environmental conditions, here shown for open air conditions.

As illustrated with red arrows, select the current level (e.g. 3000 A) and find the intersection of that level with the desired temperature-rise curve (e.g. 60 degrees Kelvin); then follow the intersection point downwards to the time scale – result as shown is 20 seconds. In twenty (20) seconds the shunt will heat-up by 60 degrees K with the current of 3000 A. This chart is for SFP Shunt, terminated with busbars that have the same cross-section as the shunt itself (108 mm<sup>2</sup>). With these connections, the shunt is capable of supporting 600 A in continuous operations, with the temperature rise of less than 100 K.

## Expected Performance Data

SFP Shunt, 18  $\mu\Omega$  Shunt with 108 mm<sup>2</sup> bus-bars

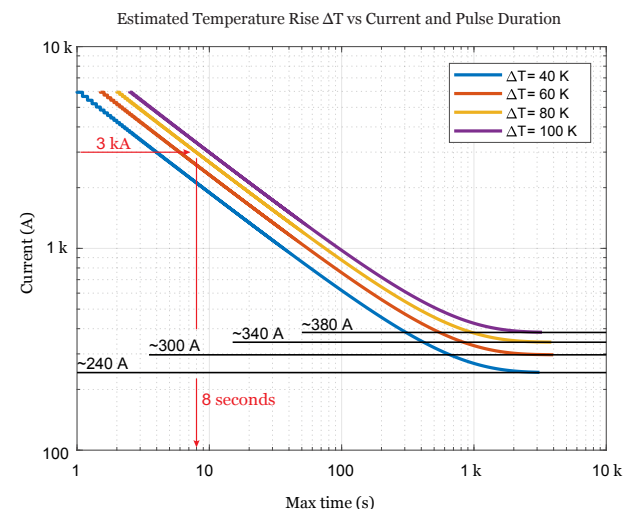

This chart is a representation of results obtained using an effective thermal shunt model for transient thermal response analysis, as developed by Sendyne's modeling team. The model accounts for specific environmental conditions, here shown for open air conditions.

As illustrated with red arrows, select the current level (e.g. 3000 A) and find the intersection of that level with the desired temperature-rise curve (e.g. 60 degrees Kelvin); then follow the intersection point downwards to the time scale – result as shown is 20 seconds. In twenty (20) seconds the shunt will heat-up by 60 degrees K with the current of 3000 A. This chart is for SFP Shunt, terminated with busbars that have the same cross-section as the shunt itself (108 mm<sup>2</sup>). With these connections, the shunt is capable of supporting 600 A in continuous operations, with the temperature rise of less than 100 K.

## SFP200MOD block diagram

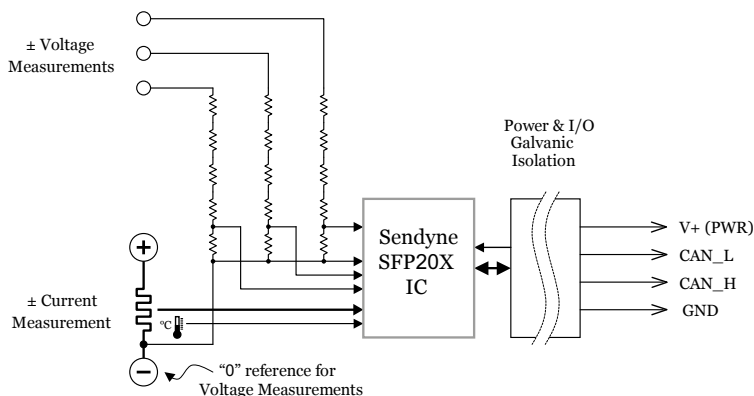

# SFP200MOD Technical Specifications

## Ordering Information

Part Number	Description
SFP200MOD-MP3	SFP200MOD module with variable power supply that can accept input of anywhere from +5 V to +53 V, with dip switch, measures up to 1500 A; datasheet reflects MP3 variation.
SFP200KIT-MP3	SFP200MOD module with variable power supply that can accept input of anywhere from +5 V to +53 V, with dip switch measures up to 1500 A, CAN to USB protocol converter for PC communication, Windows software and cables; datasheet reflects MP3 variation.
SFP200MOD-MP2	SFP200MOD module with variable power supply that can accept input of anywhere from +5 V to +53 V, with dip switch, measures up to 1250 A.
SFP200KIT-MP2	SFP200MOD module with variable power supply that can accept input of anywhere from +5 V to +53 V, with dip switch, measures up to 1250 A, CAN to USB protocol converter for PC communication, Windows software and cables.
SFP200MOD-MP1	SFP200MOD module with +5 V power supply, with dip switch, measures up to 1250 A.
SFP200KIT-MP1	SFP200MOD module with +5 V power supply, with dip switch, CAN to USB protocol converter for PC communication, Windows software and cables.

## Revision History

Revision Number	Date	Comments
1.7	12/19/2018	Typographical corrections & clarifications in electrical specifications
1.6	11/21/2017	Part numbers updated in Ordering Information
1.5	8/16/2017	Implementaion of MP3 to replace MP1 and MP2
1.4	5/26/2017	Updated electrical specs; addition of features section and expected performance data charts
1.3	5/15/2017	CAN address selection updated, offer continuously variable power supply option
1.2	4/24/2017	Updated module image
1.1	4/18/2017	Document changed to reflect minor assembly changes, 5 V power supply, dip switch addition and change of orientation of Sendyne shunt
1.0	12/8/2016	Initial release

Datasheets provided by Sensata Technologies, Inc., its subsidiaries and/or affiliates ("Sensata") are solely intended to assist third parties ("Buyers") who are developing systems that incorporate Sensata products (also referred to herein as "components"). Buyer understands and agrees that Buyer remains responsible for using its independent analysis, valuation, and judgment in designing Buyer's systems and products. Sensata datasheets have been created using standard laboratory conditions and engineering practices. Sensata has not conducted any testing other than that specifically described in the published documentation for a particular datasheet. Sensata may make corrections, enhancements, improvements, and other changes to its datasheets or components without notice.

Buyers are authorized to use Sensata datasheets with the Sensata component(s) identified in each particular datasheet. HOWEVER, NO OTHER LICENSE, EXPRESS OR IMPLIED, BY ESTOPPEL OR OTHERWISE TO ANY OTHER SENSATA INTELLECTUAL PROPERTY RIGHT, AND NO LICENSE TO ANY THIRD PARTY TECHNOLOGY OR INTELLECTUAL PROPERTY RIGHT, IS GRANTED HEREIN. SENSATA DATASHEETS ARE PROVIDED "AS IS". SENSATA MAKES NO WARRANTIES OR REPRESENTATIONS WITH REGARD TO THE DATASHEETS OR USE OF THE DATASHEETS, EXPRESS, IMPLIED, OR STATUTORY, INCLUDING ACCURACY OR COMPLETENESS. SENSATA DISCLAIMS ANY WARRANTY OF TITLE AND ANY IMPLIED WARRANTIES OF MERCHANTABILITY, FITNESS FOR A PARTICULAR PURPOSE, QUIET ENJOYMENT, QUIET POSSESSION, AND NON-INFRINGEMENT OF ANY THIRD PARTY INTELLECTUAL PROPERTY RIGHTS WITH REGARD TO SENSATA DATASHEETS OR USE THEREOF.

All products are sold subject to Sensata's terms and conditions of sale supplied at [www.sensata.com](http://www.sensata.com). SENSATA ASSUMES NO LIABILITY FOR APPLICATIONS ASSISTANCE OR THE DESIGN OF BUYERS' PRODUCTS. BUYER ACKNOWLEDGES AND AGREES THAT IT IS SOLELY RESPONSIBLE FOR COMPLIANCE WITH ALL LEGAL, REGULATORY, AND SAFETY-RELATED REQUIREMENTS CONCERNING ITS PRODUCTS, AND ANY USE OF SENSATA COMPONENTS IN ITS APPLICATIONS, NOTWITHSTANDING ANY APPLICATIONS-RELATED INFORMATION OR SUPPORT THAT MAY BE PROVIDED BY SENSATA.

Mailing Address: Sensata Technologies, Inc., 529 Pleasant Street, Attleboro, MA 02703, USA

**Sensata Technologies**  
Denmark A/S  
Greater Copenhagen  
Phone: +45 5851 5104  
Email: [lb\\_contact@sensata.com](mailto:lb_contact@sensata.com)

**Regional head offices:**  
United States of America  
Sensata Technologies  
Attleboro, MA  
Phone: 508-236-3800  
E-mail: [support@sensata.com](mailto:support@sensata.com)

Netherlands  
Sensata Technologies Holland  
B.V.  
Hengelo  
Phone: +31 74 357 8000  
E-mail: [support@sensata.com](mailto:support@sensata.com)

China  
Sensata Technologies China  
Co., Ltd.  
Shanghai  
Phone: +8621 2306 1500  
E-mail: [support@sensata.com](mailto:support@sensata.com)

[sensata.com](http://sensata.com)